



PARTS & INSTALLATION INSTRUCTIONS
MDII™ and EZ MOUNT PLUS™
SNOW PLOW MOUNTING 17124
1997-1999 FORD F150, F250 L.D.
2000-2003 FORD F150 4x4 MODELS
7,700 LB. G.V.W.R.

Non - Commercial for Personal - use ONLY

End user must be given this instruction sheet prior to delievery of this Snow Plow.

SAFETY DEFINITIONS

	This is the safety alert symbol. It is used to alert you to potential personal injury hazards. Obey all safety messages that follow this symbol to avoid possible injury or death.
	DANGER Indicates an imminently hazardous situation which, if not avoided, will result in death or serious injury.
	WARNING Indicates a potentially hazardous situation which, if not avoided, could result in death or serious injury.
	CAUTION Indicates an potentially hazardous situation which, if not avoided, may result in minor or moderate injury.
	CAUTION used without the safety alert symbol indicates a potentially hazardous situation which, if not avoided, will result in property damage.

IMPORTANT NOTICE

In conjunction with FMVSS (Federal Motor Vehicle Safety Standards) and OEM (Original Equipment Manufacturer) guidelines, Meyer Products has designed this plow package with the following guidelines:

	Installation of a snowplow may effect your new vehicle warranty. For more information consult your Vehicle Owner's Manual / Vehicle Dealer.
	The vehicle must not be operated when overloaded. In all cases, the loaded vehicle weight, including the entire snowplow system, all aftermarket accessories, driver, passenger, options, nominal fluid levels, and cargo must not exceed the front/rear Gross Axle Weight Rating (GAWR), and total Gross Vehicle Weight Rating (GVWR). These weights ratings are specified on the safety compliance certification label on the driver's side door opening. The use of rear ballast weight may be required to prevent exceeding the front GAWR.

According to the NHTSA (National Highway Traffic Safety Administration) new and untitled vehicles need to be verified by the installer that snowplow and ballast (if needed) do no exceed the front/rear GAWR and total GVWR.

	Read the Meyer Owner's Manual before operating or servicing a snowplow. FOLLOW THESE INSTRUCTIONS EXPLICITLY.
--	--

GENERAL INFORMATION

	SAFETY PRECAUTIONS should be used when Hydraulic Unit is in OPERATION and plow is in a RAISED position. Lower plow to ground when vehicle is PARKED in case of hydraulic failure.
--	---

Check contents against the parts list to determine all are correct and included, and also to familiarize yourself with them.

	Warranty does not apply to a Meyer or Diamond product which has been negligently or improperly assembled or installed.
--	--

	CAUTION: To avoid harm to vehicles electrical system always disconnect battery before beginning installation. DO NOT BURN holes or WELD vehicle frame. This may cause frame failure.
--	---

OVERHAUL and SERVICE INFORMATION are covered on separate instructions.

Meyer Products and Diamond Equipment reserves the right, under its continuing product improvement program, to change construction or design details, specifications and prices without notice or without incurring any obligation.

Meyer Products Inc.
18513 Euclid Ave. • Cleveland, Ohio 44112-1084
Phone 486-1313 (Area Code 216)
www.meyerproducts.com • email info@meyerproducts.com

Diamond Equipment
6 Angell Lane • Damariscotta, ME 04543-4507
Phone 563-2227 (Area Code 207)
www.diamondplow.com • email info@diamondplow.com



PARTS LIST

ITEM	PART NO.	QTY.	DESCRIPTION
	17124	1	MOUNTING CARTON
1	11857	1	• Side Member L.H.
2	11856	1	• Side Member R.H.
3	11607	2	• Stud Bar
4	11798	1	• Connector Bracket F150/250LD
	08741	1	• HARDWARE BAG
5	07067	2	•• Cap: Stud Bar
6	20355	12	•• Flatwasher 1/2"
7	20357	6	•• Flatwasher 5/8"
8	20096	8	•• Bolt 1/2-13 x 1-3/4"
9	20140	2	•• Bolt 5/8-11 x 1-3/4"
10	20307	8	•• Locknut Esna 1/2-13
11	20309	6	•• Locknut Esna 5/8-11
12	-----	4	•• Original Towhook Fasteners
*	19370	1	Universal Clevis (Part of Plus CLF Carton)
**	11770	1	Universal Clevis (Part of MDII CLF Carton)
STL 7.5	ST 7.5	STP 7.5	See Vehicle Recommendations
11" SECTOR			MEYER
	PART NO.	QTY.	DESCRIPTION
16520	16515	1	Sector A-Frame Carton
DIAMOND			
	81504	1	Common Attaching Kit
	81026	1	Push Frame

Parts indented are included in the carton, bag or assembly under which they are indented.

IMPORTANT

After first use, retighten all mounting bolt connections to specified torque. All mounting bolt connections to be checked periodically for tightness.

Locknuts are furnished **DO NOT** tighten bolts and nuts until installation is complete (unless otherwise specified), then be sure to tighten all attaching parts per specified torque chart.

TORQUE CHART FOOT

Bolt Nut Size	Gr. 2	Gr. 5	Gr. 8
1/4 - 20	4 - 5		
5/16 - 18	9 - 11		
3/8 - 16	17 - 20	26 - 29	
7/16 - 14		42 - 46	60 - 66
1/2 - 13		64 - 72	90 - 100
5/8 - 11		127 - 141	179 - 198

NOTE:

THIS MOUNTING CARTON CAN BE USED WITH THE MDII OR EZ MOUNT PLUS CLF CARTONS.

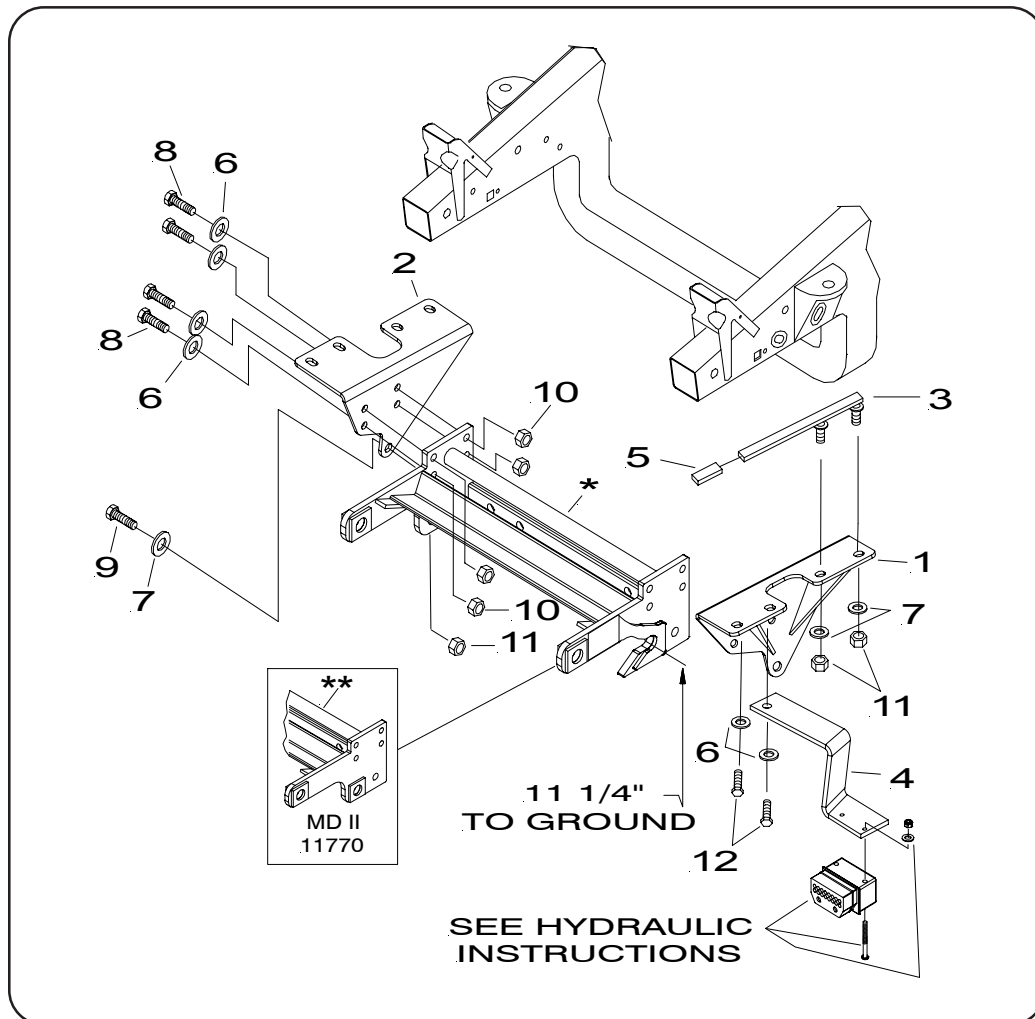

VEHICLE RECOMMENDATIONS

- 1997-1999 (139" W.B.) regular cab only Heavy Duty Optional Service Package 53C F150 -3,900 lb., F250L.D. - 3950 - 4,100 lb. front suspension as recommended by Ford Motor Company for snow plow applications.
- For 2000 (138.8" W.B.) regular or super cab only (No super crew) the F150 HD 7700 Payload Group V-8 (Option Code 627) is needed (Front G.A.W.R. 4150 lbs.)
- **Note:** STL 7.5 Moldboard is recommended on vehicles equipped with a 3,900 lb. front G.A.W.R
- **Note:** ST 7.5 Moldboard is recommended on F250 LD vehicle equipped with a 3,950 lb. Front G.A.W.R.
- **Note:** ST/STP 7.5 Moldboard is recommended on vehicles equipped with a 4,100 lb. or higher Front G.A.W.R.
- Must restrict Lariat Trim, Load leveling Suspension and Skid Plates when using 5.4L powertrains.

WARNING

- A ballast weight may be required to prevent front GAWR overloading. If required, ballast must be securely attached at least 24 inches behind the rear axle.

WARNING

- Front end wheel alignment and headlight aim may require readjustment after installation of equipment, and is the responsibility of the equipment installer. Failure to adjust front wheel alignment may cause premature uneven tire wear. If required, reset to chassis manufacture's specifications found in the Ford Shop Manual.

Rear ballast is determined by weighing a vehicle's front and rear axles and adding weight behind the rear axle until front axle weight is under or equal to the vehicle specific front GAWR while not exceeding the rear GAWR and GVWR.

Vehicle option packages may vary. If in doubt, it is always a good idea to weigh the vehicle to ensure all weight ratings are not exceeded with plow in the raised position.

INSTALLATION INSTRUCTIONS

To maintain front end alignment measure and record the front bumper height before installing any hardware. Mount all snowplow hardware, adjust torsion bars per the Ford Shop Manual's alignment procedure until the original front bumper height is achieved.

Note: Reverse this procedure when plow is removed. **Failure to follow these recommendations may cause premature tire wear and affect front end alignment.**

- A. Remove Skid Plate if vehicle is so equipped. It will not be reused. Remove bottom air dam skirt. Skirt may be reattached if desired, notching out around clevis may be required.
- B. Remove Tow Hooks, they will not be reused, retain bolts for later use. Nut Bar inside frame will also be reused.
- C. Attach L.H. & R.H. Side Members (1&2) to bottom of vehicle frame at front two holes using the original vehicle fasteners (12), 1/2" flatwashers (6) and original Nut Bars as mentioned in Paragraph B. Note: Connector Bracket (4) should be sandwiched between the LH Side Member (1) and the 1/2" flatwasher (6) when installing the second from the front bolt. The front edge of Connector Bracket (4) should be parallel with the front of the vehicle frame before tightening.

Note: Snug all bolts during the installation. Do not torque down any bolts until step F.

- D. Assemble Stud Bar Caps (5) to Stud Bars (3). Insert Stud Bars (3) thru front of vehicle frame and extend bolts thru square holes in bottom of vehicle frame and through the rear holes of Side Members (1&2). Attach with 5/8" washers (7), and 5/8-11 locknuts (11).
- E. Attach L.H. & R.H. Side Members (1&2) to the Universal Clevis (*) using 1/2-13 x 1-3/4" bolts (8), 1/2" flatwashers (6), and 1/2-13 locknuts (10) in the upper 4 holes. Also attach using 5/8-11 x 1-3/4" bolts (9), 5/8" flatwashers (7), and 5/8-11 locknuts (11) in the lower holes.

Note: Before tightening the fasteners, the clevis frame (*) should be level with the ground and pushed back as far under the vehicle as possible.

- F. Tighten all fasteners to their proper torque. Tighten bolts in the same order they were assembled.
- G. Install remaining snowplow hardware per separate instructions.

Meyer Products or Diamond Equipment assumes no responsibility for installations not made in accordance with these instructions.