

PARTS & INSTALLATION INSTRUCTIONS

SNOW PLOW MOUNTING

1999 GMC and Chevrolet C 2500 Series 4x2 Models

IMPORTANT NOTICE

End user must be given this instruction sheet prior to delivery of this Snow Plow.

The equipment you have just purchased should only be used on vehicles equipped with the Manufacturer's Snow Plow Preparation Packages. Snow Plowing without the original Snow Plow Preparation Package may damage your vehicle and the added weight to the equipment may impair the operation and control of the vehicle. Snow Plowing with a vehicle that the manufacturer does not recommend for that purpose may void your new vehicle warranty. If your vehicle is not originally equipped with the Snow Plow Package, additional parts may be necessary before snow plowing. Owners of these vehicles should consult their dealers before purchase or installation of such parts. CAUTION: the installation, on any vehicle, of these parts is not a full substitute for the original equipment Snow Plow Preparation Package. General Motors recommends the Snow Plow Preparation Package VYU.

Warning: Lift Arm extends beyond bumper of vehicle. To minimize damage from a front-end collision, Lift Arm should be removed from vehicle when Snow Plow is removed.

Note: Vehicles equipped without Tow Hooks will require an additional hardware bag part number 08776.

PART LIST

Item	Part No.	Qty.	Description
	17114	1	MOUNTING CARTON
1	11685	1	• Clevis Frame
2	10514	1	• Lift Arm
3	22223	2	• Handle Bolt w/Washer
4	11544	2	• Receiver Tube Cap
	08716	1	• HARDWARE BAG
5	11006	2	•• Hinge Pin
6	11636	2	•• Sleeve
7	20144	1	•• Bolt H 5/8-11 x 2-3/4" Gr. 5
8	20146	2	•• Bolt H 5/8-11 x 3-1/4" Gr. 5
9	20153	2	•• Bolt H 5/8-11 x 5-1/2" Gr.5
10	22182	4	•• Bolt HM12 x 1.75 x 40 mm Gr.10.9
11	20355	4	•• Flatwasher 1/2"
12	20357	8	•• Flatwasher 5/8"
13	20309	7	•• Locknut Esna 5/8-11
14	21984	2	•• Hair Pin Cotter
	21976	2	•• Battery Connectors
	11734	2	•• Stop Plates 2" x 2" x 1/4"
15	11255	1	LIFT FRAME (Tubular)
11" Sector			
Item	Part No.	Qty.	Description
	16505	1	SECTOR - A-FRAME CARTON
16	12326	1	• Sector
	13612	1	• A- Frame
	07017	3	• Trip Spring
	09916	1	• Marker Kit
	08166	1	• PLOW HARDWARE BAG
17	09119	2	•• Pivot Pin w/Cotter
	11101	2	•• Hinge Pin
18	22083	2	•• Linch Pin
	09122	1	•• King Bolt w/Locknut
	09124	3	•• Eye Bolt w/Locknuts
	08776	1	Hardware Bag (Optional)
19	11636	2	• Sleeve
20	20096	2	• Bolt H 1/2-13 x 1-3/4" Gr.5
21	20107	2	• Bolt H 1/2-13 x 5" Gr.5
22	20307	4	• Esna Nut 1/2-13
23	20355	8	• Flatwasher 1/2"

Parts indented are included in the carton, bag or assembly under which they are indented. When ordering parts, furnish Part No., Name, and Description. Also furnish Vehicle Model and Year. Type of Hydraulic Unit and Moldboard Size.

Meyer Products reserves the right, under its continuing product improvement program, to change construction or design details, specifications and prices without notice or without incurring any obligation.

GENERAL INFORMATION

CAUTION: Always disconnect battery before beginning installation.

DO NOT BURN holes or **WELD** vehicle frame. This may cause frame failure.

After first use, retighten all mounting bolt connections to specified torque. All mounting bolt connections to be checked periodically for tightness.

Locknuts are furnished **DO NOT** tighten bolts and nuts until installation is complete (unless otherwise specified), then be sure to tighten all attaching parts per specified torque chart.

NOTE: It is important that the Meyer harness, all wires from the Meyer light switch, and all other electrical wires be routed around hot or moving engine parts, and any sharp metal. Protection must be provided to guard against wire damage at these points. All excess or loose wires must be neatly secured using wire ties.



Check contents against the parts list to determine all are correct and included, and also to familiarize yourself with them.

SAFETY PRECAUTIONS should be used when **Hydraulic Unit is in OPERATION** and plow is in a **RAISED** position. Lower plow to ground when vehicle is **PARKED**.

OVERHAUL and **SERVICE INFORMATION** are covered on separate instructions.

Follow these instructions explicitly. Warranty does not apply to a Meyer product which has been negligently or improperly assembled or installed.

TORQUE CHART FOOT LBS.

Bolt Nut Size	Gr. 2 	Gr. 5 	Gr. 8 
1/4 - 20	4 - 5		
5/16 - 18	9 - 11		
3/8 - 16	17 - 20	26 - 29	
7/16 - 14		42 - 46	60 - 66
1/2 - 13		64 - 72	90 - 100
5/8 - 11		127 - 141	179 - 198
3/4 - 10		227 - 251	

Meyer Products assumes no responsibility for installations not made in accordance with these instructions.

Without Tow Hook

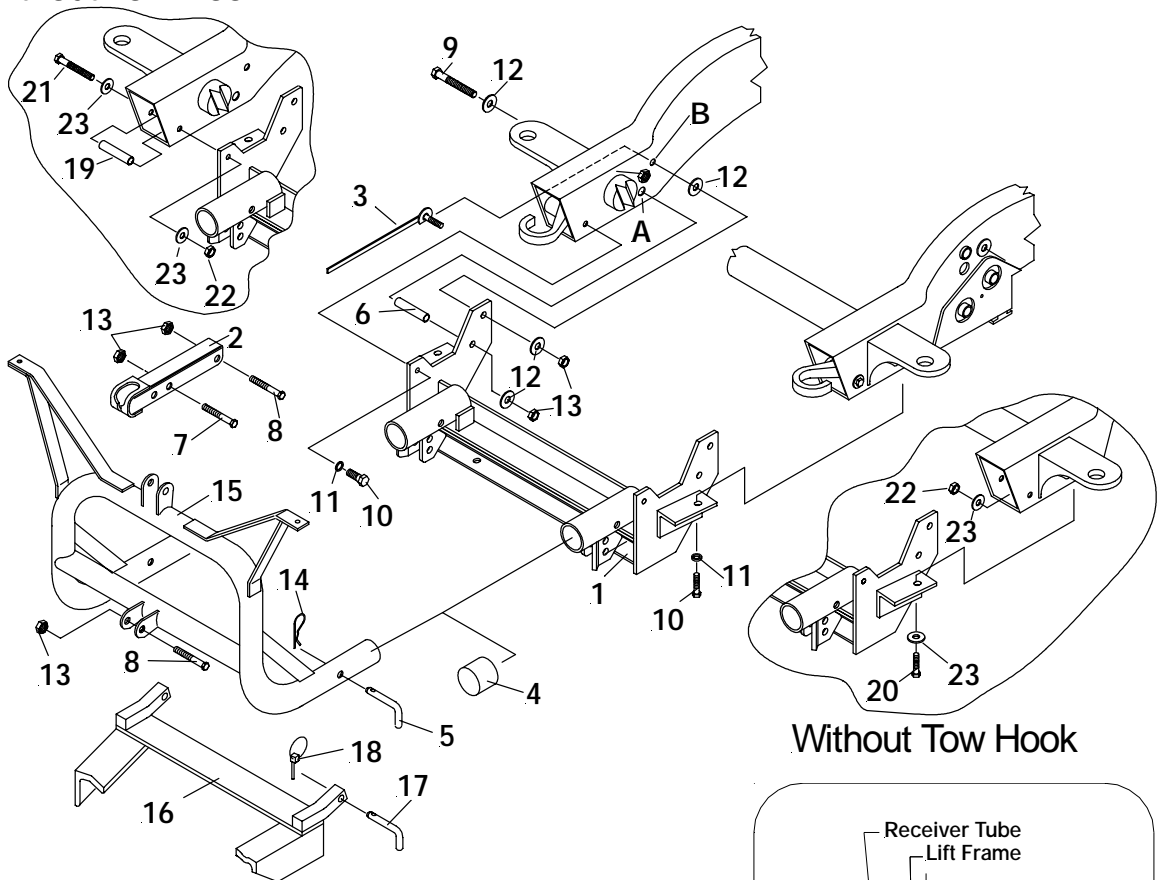

Without Tow Hook

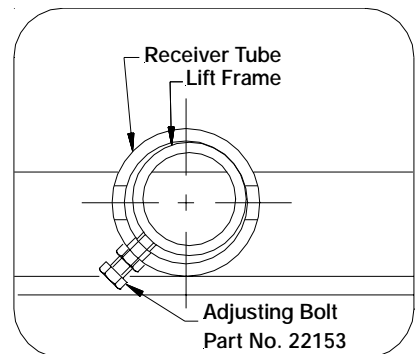

INSTALLATION INSTRUCTIONS

- A. Remove air dam. Retain all hardware. The air dam may be reinstalled.
- B. If vehicle is equipped with Tow Hooks, remove tow hook bolts from the bottom flange and inside of the frame rail on both driver and passenger sides. Retain hardware. They will not be reused.
- C. Position clevis frame (1) between frame rails and align to where tow hook bolts were removed. Attach clevis frame to the inside and bottom of vehicle frame using M12 x 1.75 x 40mm bolts (10), washers (11). **Do not tighten at this time.**

Without Tow Hooks

Position clevis frame (1) between frame rails and align to where tow hook bolts would be. See Illustration. Attach clevis frame to front of vehicle frame using 1/2-13 x 5" bolt (21), Sleeve (19), washers (23) and locknut (22). Attach clevis frame (1) to the bottom of vehicle frame using 1/2-13 x 1-3/4" bolt (20), washers (23) and locknut (22). **Do not tighten at this time.**

- D. Using the clevis frame (1) as a template, drill a 21/32" hole all the way through the frame rails at hole "A" and at hole "B" drill a 21/32" hole through the **inside section of the frame rail only**.
- E. Remove clevis (1) and re-drill **only** the inside section of the frame rails at hole "A" with a 27/32" bit. This will allow for the installation of sleeve (6).
- F. Reposition the clevis frame (1) between the vehicle frame rails and reattach using M12 x 1.75 x 40mm bolts (10), washers (11).

Without Tow Hooks

Reposition clevis frame (1) between frame rails. Re-attach clevis frame to front of vehicle frame using 1/2-13 x 5" bolt (21), Sleeve (19), washers (23) and locknut (22). Attach clevis frame (1) to the bottom of vehicle frame using 1/2-13 x 1-3/4" bolt (20), washers (23) and locknut (22). See Illustration. **Do not tighten at this time.**

- G. Attach clevis frame (1) at hole "A" using 5/8-11x 5-1/2" bolt (9), sleeve (6), washers (12), and locknut (13), See illustration. **Do not tighten at this time.**

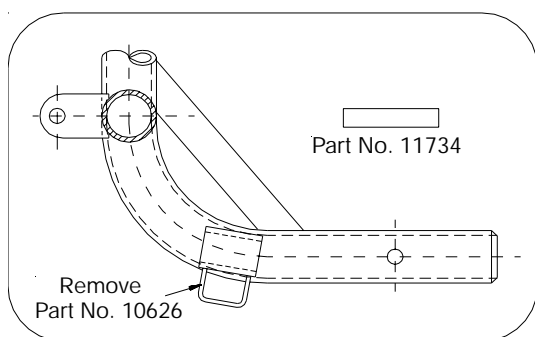

- H. Guide handle bolt w/washer (3) through vehicle frame pushing bolt out the top hole in clevis frame. Attach using washers (12) and locknuts (13). Per illustration .
- I. Tighten all fasteners to their proper torque. Tighten bolts in the same order they were assembled to the vehicle.
- J. Reinstall air dam if desired, notch out around clevis frame as needed.

Important Notice: Current production lift frames have additional stops (Part No. 10626) tack welded to the existing stops. (See illustration.) Depending upon the S.A.F. Carton being installed, additional stops may need to be added or removed.

- K. When installing S.A.F. Carton 16505, lift frame should **NOT** have the additional stops (Part No. 10626) Remove 10626 stops and replace with 11734 stops plates.

Note: Before installing lift frame tubing to clevis frame, liberally coat ends of lift frame with chassis grease / anti-seize lubricant.

- L. Install Lift Frame (15) into the tubes on the clevis frame. Turn adjusting bolts in until contact is made with lift frame.

Caution: Do not over tighten adjustment bolts. Adjust bolts for minimum clearance between lift frame and receiver tubes while still allowing for ease of lift frame removal. See illustration. Secure lift frame (15) to clevis frame (1) using hinge Pins (5) and hair pin cotters (14).

- M. Attach lift arm (2) to lift frame (15) using 5/8-11 x 3-1/4" bolt (8) and locknut (13). Mount Hydraulic unit to lift frame using 5/8-11 x 3-1/4" bolt (8) and locknut (13), and to lift arm (2) using 5/8-11 x 2-3/4" bolt (7) and locknut (13). **(SEE WARNING)**
- N. Install hydraulic system and snow plow lights per separate instructions.
- O. Pre-Assemble Moldboard Assembly, A-Frame (16), Sector, ect., per separate instructions.
- P. Hook the A-Frame chain to the Lift Arm (2) allowing sufficient slack to enable the Moldboard to follow ground contour while plowing.

Note: When the lift frame module (15) is removed from the vehicle, the insides of the clevis frame (1) receiver tubes and outside ends of the lift frame should be coated with chassis grease/anti-seize lubricant and the protective receiver tube caps (4) install over the clevis frame receiver tubes.