



PARTS & INSTALLATION INSTRUCTIONS

MEYER SNOW PLOW MOUNTING

1999 & LATER FORD F250 H.D. & F350 PICK-UP SUPERDUTY 4x4 VEHICLES

IMPORTANT NOTICE

End user must be given this instruction sheet prior to delivery of this Snow Plow.

The equipment you have just purchased should only be used on vehicles equipped with the Manufacturer's Snow Plow Preparation Packages. Snow Plowing without the original Snow Plow Preparation Package may damage your vehicle and the added weight to the equipment may impair the operation and control of the vehicle. Snow Plowing with a vehicle that the manufacturer does not recommend for that purpose may void your new vehicle warranty. If your vehicle is not originally equipped with the Snow Plow Package, additional parts may be necessary before snow plowing. Owners of these vehicles should consult their dealers before purchase or installation of such parts. CAUTION: the installation, on any vehicle, of these parts is not a full substitute for the original equipment Snow Plow Preparation Package.

Warning: Lift Arm extends beyond bumper of vehicle. To minimize damage from a front-end collision, Lift Arm should be removed from vehicle when Snow Plow is removed.

PARTS LIST

Item	Part No.	Qty.	Description		
	17112	1	MOUNTING CARTON		
1	11660	1	• Clevis Frame		
2	11773	1	• Side Mount Weldment L.H.		
3	11652	1	• Side Mount Weldment R.H.		
4	11775	1	• Side Plate Weldment L.H.		
5	11646	1	• Side Plate Weldment R.H.		
6	10514	1	• Lift Arm		
7	11544	2	• Receiver Tube Cap		
	13615	2	• Lift Frame Stops		
	08626	1	• Kit, Light Elevation		
8	11368	2	•• Bracket		
9	20095	2	•• Bolt 1/2-13 x 1-1/2" Gr.5		
10	20307	2	•• Locknut Esna 1/2-13		
	08708	1	• HARDWARE BAG		
11	11006	2	•• Hinge Pin		
12	11661	2	•• Sleeve		
13	11968	2	•• Spacer		
14	14595	2	•• Special Bolt 3/4"		
15	20096	4	•• Bolt H 1/2-13 x 1-3/4" Gr. 5		
16	20098	4	•• Bolt H 1/2-13 x 2-1/4" Gr.5		
17	20141	8	•• Bolt H 5/8-11 x 2" Gr.5		
18	20144	1	•• Bolt H 5/8-11 x 2-3/4" Gr. 5		
19	20146	2	•• Bolt H 5/8-11 x 3-1/4" Gr.5		
20	20153	2	•• Bolt H 5/8-11 x 5-1/2" Gr.5		
21	20307	8	•• Locknut Esna 1/2-13		
22	20309	13	•• Locknut Esna 5/8-11		
23	20310	2	•• Locknut 3/4-10		
24	20355	16	•• Flatwasher 1/2"		
25	20357	2	•• Flatwasher 5/8"		
26	20359	2	•• Flatwasher 3/4"		
27	21984	2	•• Hair Pin Cotter		
	11688	2	•• 2" x 2" x 3/4" Flat Stock		
28	11255	1	LIFT FRAME (Tubular)		
	11" Sector		15" Sector		
Item	Part No.	Qty.	Part No.	Qty.	Description
	16505	1	16504	1	SECTOR -A-FRAME CARTON
	12326	1	12793	1	• Sector
29	13612	1	13608	1	• A- Frame
	07017	3	07017	4	• Trip Spring
	09916	1	09916	1	• Marker Kit
	08166	1	08341	1	• PLOW HARDWARE BAG
	09119	2	09119	2	•• Pivot Pin w/Cotter
30	11101	2	11101	2	•• Hinge Pin
31	22083	2	22083	2	•• Linch Pin
	09122	1	09125	1	•• King Bolt w/Locknut
	09124	3	09124	4	•• Eye Bolt w/Locknuts

Parts indented are included in the carton, bag or assembly under which they are indented.

Meyer Products reserves the right, under its continuing product improvement program, to change construction or design details, specifications and prices without notice or without incurring any obligation.



GENERAL INFORMATION

CAUTION: Always disconnect battery before beginning installation.

DO NOT BURN holes or **WELD** vehicle frame. This may cause frame failure.

After first use, retighten all mounting bolt connections to specified torque. All mounting bolt connections to be checked periodically for tightness.

Locknuts are furnished **DO NOT** tighten bolts and nuts until installation is complete (unless otherwise specified), then be sure to tighten all attaching parts per specified torque chart.

NOTE: It is important that the Meyer harness, all wires from the Meyer light switch, and all other electrical wires be routed around hot or moving engine parts, and any sharp metal. Protection must be provided to guard against wire damage at these points. All excess or loose wires must be neatly secured using wire ties.

Check contents against the parts list to determine all are correct and included, and also to familiarize yourself with them.

SAFETY PRECAUTIONS should be used when **Hydraulic Unit** is in **OPERATION** and plow is in a **RAISED** position. **Lower plow to ground when vehicle is PARKED.**

OVERHAUL and **SERVICE INFORMATION** are covered on separate instructions.

Follow these instructions explicitly. Warranty does not apply to a Meyer product which has been negligently or improperly assembled or installed.

Vehicles must have heavy duty front end equipment as recommended by Ford Motor Company for snow plow applications. **(Check Body Builders Manual)**



**Snow Plow Package option Code 86M.
1999 & later F250HD & F-350**

**SuperDuty Pick-Up / Cab Chassis (4x4) Vehicles
(V) = 5200 lb. front suspension.**

Spring identification (V) can be found in the lower right hand corner of tag located in the driver's side door jam.

Reference Service Bulliten # 177.

TORQUE CHART FOOT LBS.

Bolt Nut Size	Gr. 2	Gr. 5	Gr. 8
			
1/4 - 20	4 - 5		
5/16 - 18	9 - 11		
3/8 - 16	17 - 20	26 - 29	
7/16 - 14		42 - 46	60 - 66
1/2 - 13		64 - 72	90 - 100
5/8 - 11		127 - 141	179 - 198
3/4 - 10		227 - 251	

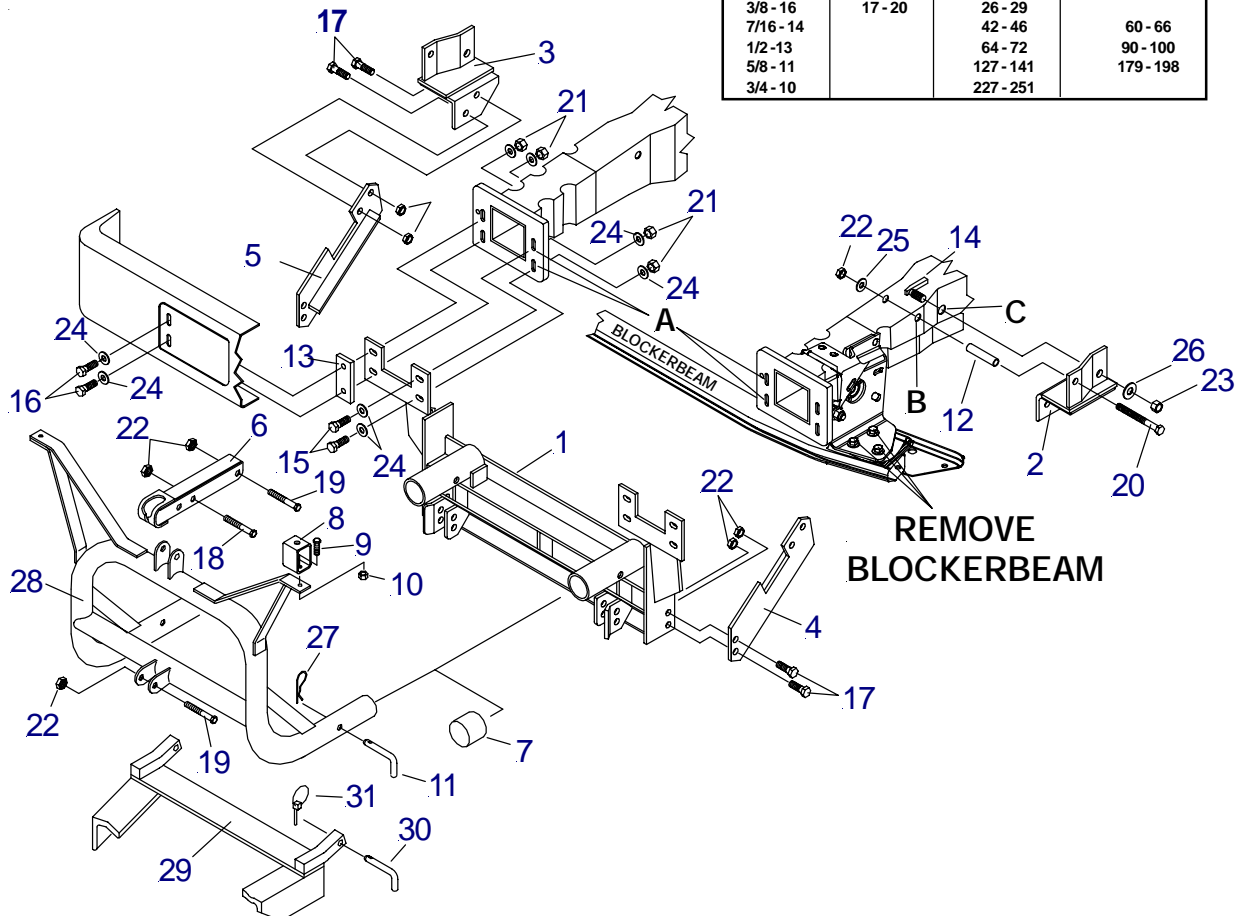

INSTALLATION INSTRUCTIONS

- A. Carefully remove vehicle Air Dam from vehicle bumper. Air Dam will be reinstalled later.
- B. Remove bumper and 1/8" bumper mounting plates from vehicle frame. Retain bumper mounting plates and hardware. They will not be reused. **Caution: Regular Cab trucks equipped with diesel engines have a light harness attached to the inside of the bumper. Detach harness before removing the bumper.**
- C. If equipped, remove Blocker Beam and retain hardware. They will not be reused.
- D. Once bumper is removed from the vehicle, attach the clevis Frame (1) to the inside slots "A" on front of vehicle frame horns using 1/2-13 x 1-3/4" bolts (15), flatwasher (24) and locknuts (21).
- E. Reinstall the bumper using 1/2-13 x 2-1/4" bolts (16), flatwashers (24), Spacers (13) and locknuts (21). **Note: Spacer (13) is to be added between the bumper and clevis frame (1) as per illustration.**
Snug bolts, do not tighten clevis frame at this time.
- F. Attach Side plate weldments (4&5) to clevis frame (1) and to Sidemounts (2&3) using 5/8-11 x 2" bolts (17), and locknuts (22). Do not tighten bolts at this time.
- G. Loosely attach sidemounts (2&3) to side plates using 5/8-11 x 2" bolts (17), and locknuts (22). Do not tighten bolts at this time.
- H. Holding sidemounts (2 & 3) tight to the bottom and side of the vehicle frame, use sidemounts as a template and scribe hole locations to be drilled "B" and "C" per illustration. Remove sidemounts.
- I. At scribed hole "B" in vehicle frame, drill a 11/16" hole thru both sides of the vehicle frame. Enlarge hole "B" to 7/8" drilling thru only the outside section of the vehicle frame to accommodate Sleeve (12).
- J. At scribed hole "C" in vehicle frame drill a 1" diameter hole, drilling thru only the outside section of the vehicle frame.

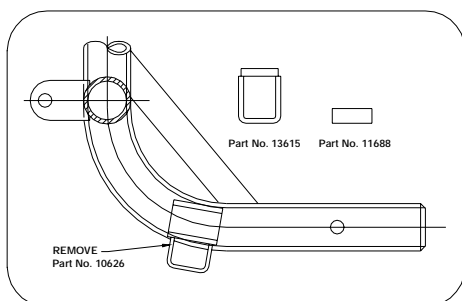
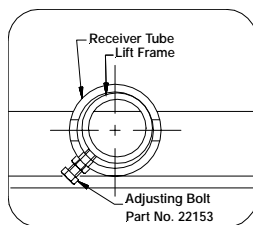

- K. Reattach sidemounts (2 & 3) to vehicle frame at hole "B" using 5/8-11 x 5-1/2" bolt (20), sleeve (12), Flatwasher (25) and locknut (22). At hole "C" using special bolt (14), flatwasher (26) and locknut (23). Reattach Side plate weldments (4&5) to Side mounts (2&3) using 5/8-11 x 2" bolts (17), and locknuts (22).

Note: Before tightening the fasteners, the clevis frame (1) should be pushed back as far as possible under the vehicle.

- L. Tighten all fasteners to their proper torque. Tighten bolts in the same order they were assembled to the vehicle.

Important Notice: Prior to installation of the lift frame (28), it will be necessary to identify the lift frame being installed. Current production lift frames have additional stops (Part No. 10626) tack welded to the existing stops. (See illustration.) Depending upon the S.A.F. Carton being installed, additional stops may need to be added or removed.

- M. When installing S.A.F. Carton 16505 remove stops 10626, replace additional stops with (Part No. 13615).

When installing S.A.F. Carton 16504 remove stops 10626, replace additional stops with (Part No. 11688).

Note: Before installing lift frame tubing to clevis frame, liberally coat ends of lift frame with chassis grease / anti-seize lubricant.

- N. Install Lift Frame (28) into the tubes on the clevis frame. Turn adjusting bolts in until contact is made with lift frame.

Caution: Do not over tighten adjustment bolts. Adjust bolts for minimum clearance between lift frame and receiver tubes while still allowing for ease of lift frame removal. See illustration.

- O. Secure lift frame (28) to clevis frame (1) using hinge pin (11) and hair pin cotter (27).

- P. Attach lift arm (6) to lift frame (28) using 5/8-11 x 3-1/4" bolt (19) and locknut (22). Mount Hydraulic unit to lift frame using 5/8-11 x 3-1/4" bolt (19) and locknut (22), and to lift arm (6) using 5/8-11 x 2-3/4" bolt (18) and locknut (22).

(SEE LIFT ARM WARNING)

- Q. Install hydraulic system and snow plow lights per separate instructions.

- R. Pre-Assemble Moldboard Assembly, A-Frame (29), Sector, ect., per separate instructions.

- S. Attach the A-Frame chain to the Lift Arm (6) allowing sufficient slack to enable the Moldboard to follow ground contour while plowing.

Note: When the lift frame module (28) is removed from the vehicle, the insides of the clevis frame (1) receiver tubes and outside ends of the lift frame should be coated with chassis grease/anti-seize lubricant and the protective receiver tube caps (7) install over the clevis frame receiver tubes.

Meyer Products assumes no responsibility for installations not made in accordance with these instructions.